

## INQUIRY SHEET OF EMBA

No. 序号	Item name 项目名称	Content provisions 内容规定
1	Inquiry company information 询价公司信息	Company name:EMBA Elektrik Uretim A.S.(Hunutlu Power Plant) 公司名称: EMBA Elektrik Uretim A.S.(Hunutlu Power Plant)
		Address:Şefik Sokak No.5 34330 Levent-Beşiktaş İstanbul 地址: Şefik Sokak No.5 34330 Levent-Beşiktaş İstanbul
		Hunutlu Power Plant Address: Akyuva district, EMBA Cluster House No.1, Yumurtalik, Adana, Turkey 胡努特鲁发电厂地址: Akyuva district, EMBA Cluster House No.1, Yumurtalik, Adana, Turkey
		Phone:05393048147 (Mr. HOU) zhenchaohou@embapower.com 联系电话: 05393048147 【Mr. HOU】 zhenchaohou@embapower.com
2	Inquiry subject 询价主题	<b>Outsourcing of parts processing</b> <b>配件委外加工</b>
3	Scope and detailed requirements 范围和详细要求	See annex for details - machining drawings 详见附件-加工图纸
4	Planned service duration 计划服务期限	Planned start date 11 July 2024, planned end date 14 July 2024 计划开始时间2024年07月11日, 计划结束时间2024年07月14日
5	Pick-up and delivery locations 取货送货地点	Turkey Hunutlu Thermal Power Plant(Sugözü District, Yumurtalik City, Adana Province, Turkey;
6	Quotation requirements 报价要求	The currency of quotation is the Turkish lira or the United States dollar or the euro, and the price is fixed for the duration of the contract. 报价货币为土耳其里拉或美元或欧元, 在合同执行期间价格固定不变
		The price shall include the stamp duty required to be paid by both parties to the procurement contract (all to be borne by the contractor and to be paid by the contractor at the relevant tax authorities); 价格应包含采购合同双方需要缴纳的印花税 (均由承包人承担, 并由承包人负责去相关税务部门缴纳);
		The quotation includes all costs for completing all the work required by the processing drawings, including but not limited to: processing costs, material costs, packaging costs, pick-up and delivery costs, loading and unloading costs, transport costs, risk costs, profits, taxes, and other costs; 报价包含完成加工图纸要求的全部工作内容的全部费用, 包括但不限于: 加工费、材料费、包装费、取货和送货费用、装卸费、交通费、风险费、利润、税金, 等全部费用;
7	Quotation Deadline 报价截止时间	<b>on 10 July 2024, at 12 a.m.</b> <b>2024年7月10日, 上午12点</b>
8	Quotation method 报价方式	Provide a signed and sealed version of the offer document 提供签字盖章版的报价文件
9	Price form 价格形式	Fixed lump-sum price, which is fixed for the duration of the contract, without any additional payment by the employer 固定总价, 合同执行期间价格固定不变, 雇主不额外支付任何其他费用
10	Settlement method 结算方式	Settlement of accounts after completion of services and passing of final acceptance 服务完成, 通过最终验收后, 办理结算
11	Method of payment 支付方式	No advance payment 无预付款
		Completion payments: Upon receipt by the Employer of a VAT invoice from the Contractor that meets the Employer's requirements, payment will be made within 30 working days at 100 per cent of the amount invoiced for Lira, with no quality assurance guarantee 完工款: 雇主收到承包人提供的满足雇主要求的增值税发票后, 30个工作日内按照发票里拉金额的100%支付, 无质量保证金
		The currency of payment is Turkish Lira, and the exchange rate of USD or EUR converted to Turkish Lira is chosen from the foreign exchange buying rate published in [Indicative Exchange Rates] on TCMB website on the day of invoice date or one day before the invoice date, and the risk of exchange rate is borne by the contractor, so please take into account the risk of exchange rate fluctuation in the quotation; 付款货币为土耳其里拉, 美元或欧元折算土耳其里拉的汇率选用发票日期当天或者发票日期前一天, TCMB网站公布的【Indicative Exchange Rates】中的外汇买入汇率, 汇率风险有承包人承担, 请在报价中考虑汇率波动风险;
12	Language 语言	English is the official language of this inquiry, and the companies participating in the quotation declare that they fully understand the contents expressed in English in this inquiry announcement. 英语作为本次询价的正式语言, 参与报价的公司声明充分理解本询价公告中英语所表达的内容
12	Documents to be sent when quoting 报价时需要发送的文件	<b>*The Qualification documents issued by the Turkish government for for carrying out such supply.</b> <b>*由土耳其政府颁发的进行此类供应的资格文件。</b>
		<b>*Business license of enterprise legal person;</b> <b>*企业法人的营业执照;</b>
		<b>*Valid and up-to-date Trade Registry Gazette;</b> <b>*有效的和最新的贸易登记公报;</b>
		<b>*Valid and updated Signature Circular;</b> <b>*有效的和更新的签署通知;</b>

## INQUIRY SHEET OF EMBA

No. 序号	Item name 项目名称	Content provisions 内容规定
		<p>*Valid and up-to-date Tax Certificate; *有效的和最新的税务证书;</p> <p>*Annex 1 Bill of Quantities (Signature and seal) . *附件1 BOQ (签名和盖章版本)。</p> <p>*Other documents if necessary. *如有必要, 还有其他文件。</p>
<p><b>Thank you for your cooperation, looking forward to your quotation!</b></p>		

## Bill of Quantities Quotation

From:EMBA ELEKTRİK ÜRETİM A.Ş.

No.	ITEM	Measurement Content	Unit	Estimate Qty.	UNIT PRICE	TOTAL PRICE	REMARKS
1	Coal Mill Roller Seat Cover Processing 磨煤机磨辊座盖加工	The material will be supplied by EMBA and the contractor will be responsible for picking up the material, machining and grinding it according to the drawings and delivering it; 材料由EMBA提供, 承包人负责取货, 根据图纸加工研磨, 送货;	Set	1.00		0.00	See process drawing 1 for details 详见加工图1
2	Coal Mill Roller Flange Machining 磨煤机磨辊法兰加工	Raw materials will be supplied by the contractor and processed according to drawings and delivered; Provision of material analyses; Provision of finished technical drawings; 原材料由承包人提供, 并根据图纸加工, 送货; 提供材料分析报告; 提供完工技术图纸;	Set	1.00		0.00	See process drawing 2 for details 详见加工图2
3	Feed pump mechanical seal water temperature measurement cylinder plugging device processing 给水泵机械密封水温度测量筒堵漏装置加工	Raw materials will be supplied by the contractor and processed according to drawings and delivered; Provision of material analyses; Provision of finished technical drawings; 原材料由承包人提供, 并根据图纸加工, 送货; 提供材料分析报告; 提供完工技术图纸;	Set	2.00		0.00	See process drawing 3 for details 详见加工图3
	Ammonia system compressor shaft machining 氨系统压缩机轴加工	Raw materials will be supplied by the contractor and processed according to drawings and delivered; Provision of material analyses; Provision of finished technical drawings; 原材料由承包人提供, 并根据图纸加工, 送货; 提供材料分析报告; 提供完工技术图纸;	Set	1.00		0.00	See process drawing 4 for details 详见加工图4

## Bill of Quantities Quotation

From:EMBA ELEKTRİK ÜRETİM A.Ş.

No.	ITEM	Measurement Content	Unit	Estimate Qty.	UNIT PRICE	TOTAL PRICE	REMARKS
	Ammonia system compressor piston cylinder machining and grinding 氨系统压缩机活塞缸加工研磨	The material will be supplied by EMBA and the contractor will be responsible for picking up the material, machining and grinding it according to the drawings and delivering it; 材料由EMBA提供, 承包人负责取货, 根据图纸加工研磨, 送货;	Set	1.00		0.00	See process drawing 4 for details 详见加工图4
TOTAL(Excluding VAT)						0.00	
VAT TAX (20%)						0.00	
TOTAL(Including VAT)						0.00	

0 E025000712040000  
0 K7006.12-14

其余  $\sqrt{25}$

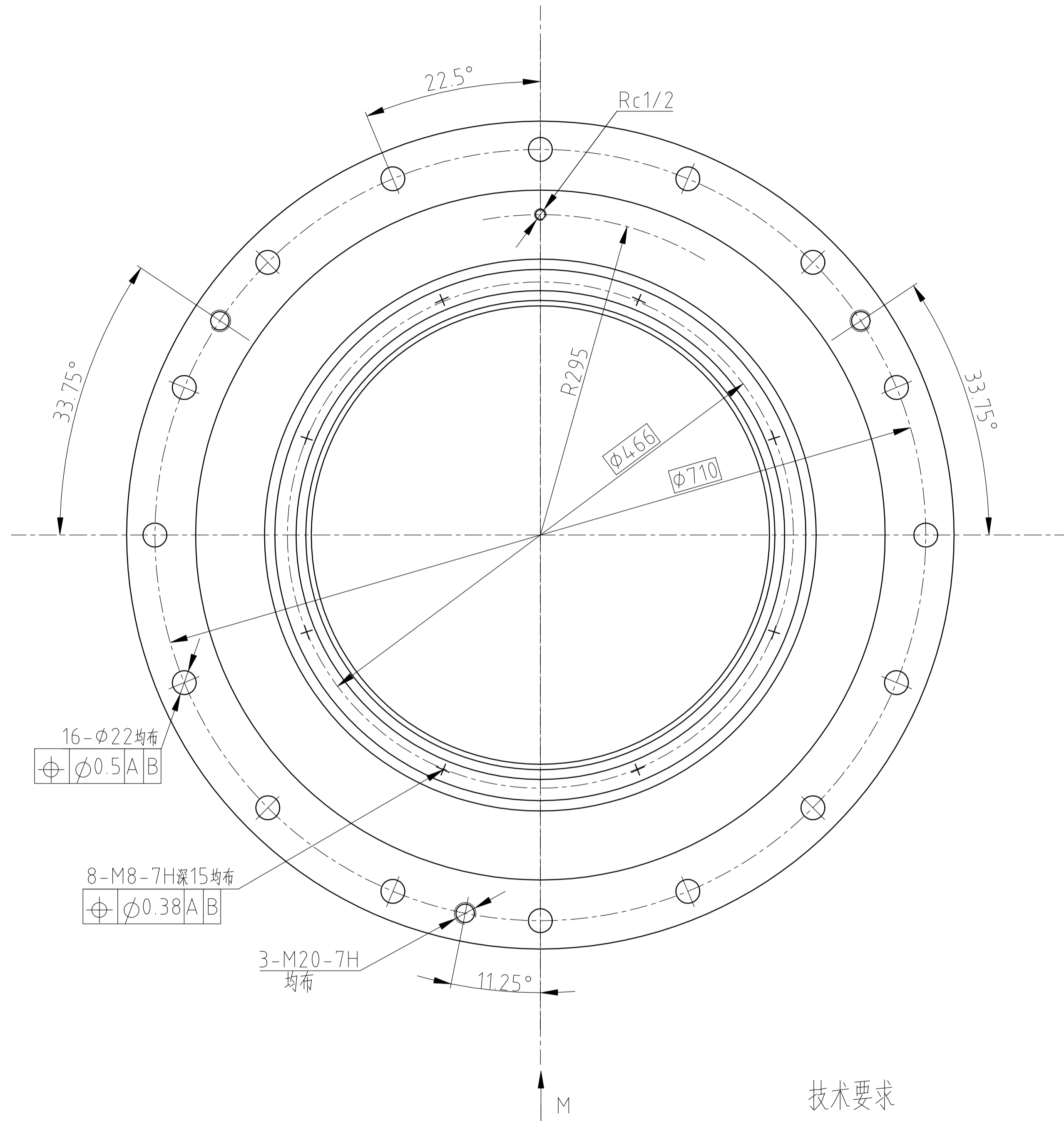
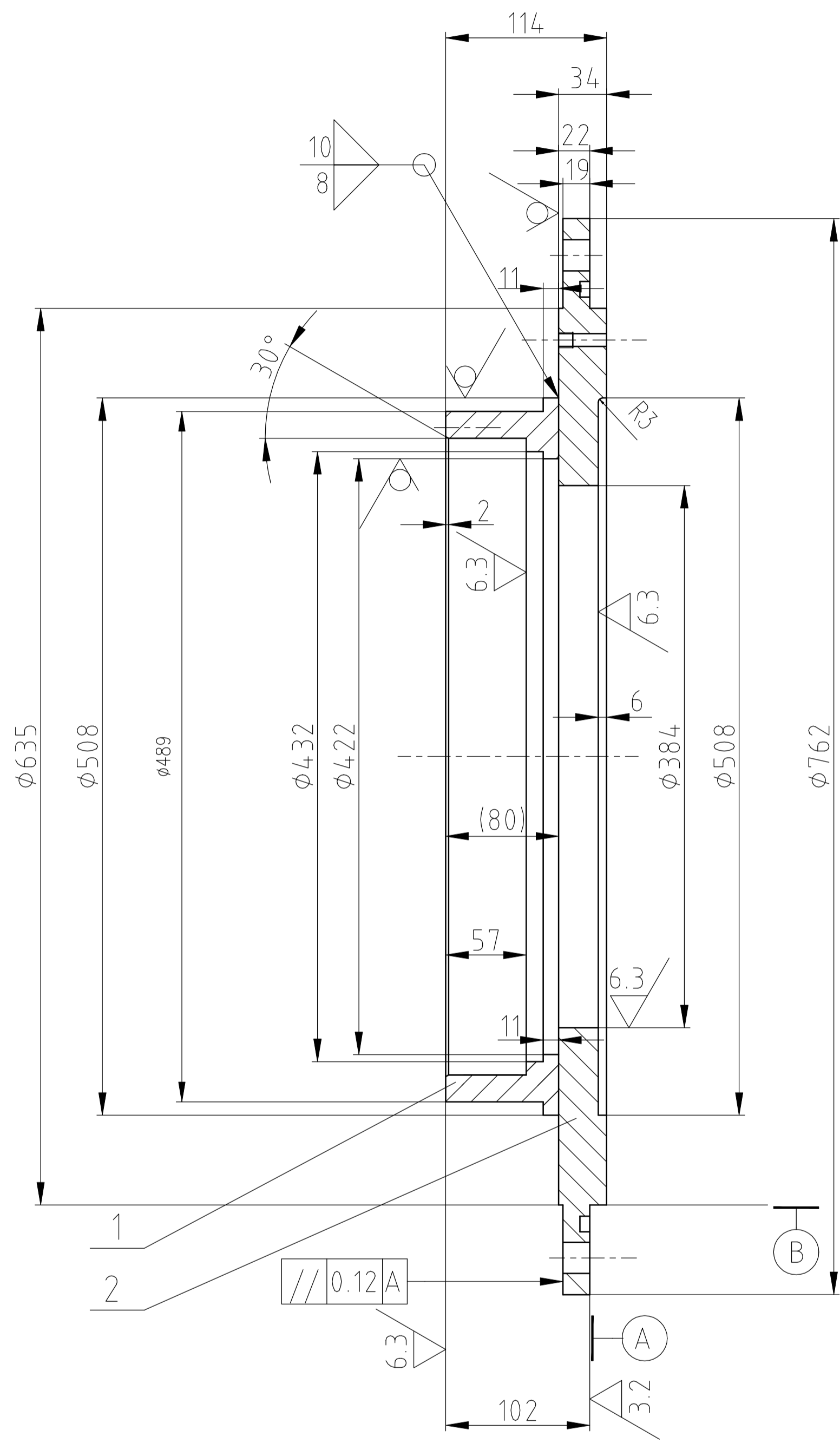

技术要求  
所有机加工为焊后加工。

本图纸版权归上海电气上重碾磨特装设备有限公司所有，图纸内容受知识产权法或涉及商业秘密相关法律法规保护，未经上海电气上重碾磨特装设备有限公司书面授权，任何单位和个人不得将图纸内容复制或透漏给第三方。

通用技术条件 JB/T 5000					上海电气上重碾磨特装设备有限公司	
磨辊座盖					重量	比例
					96	1:4
共 1 张					第 1 张	
K7006.12-14					0	
焊接件					E025000712040000 0	

标记	处数	区段	文件号	签字	日期
设计	李治宝			黄坚璋	
校对	李治宝			王爱萍	
审核	吴正华				
日期 2012.10.14					







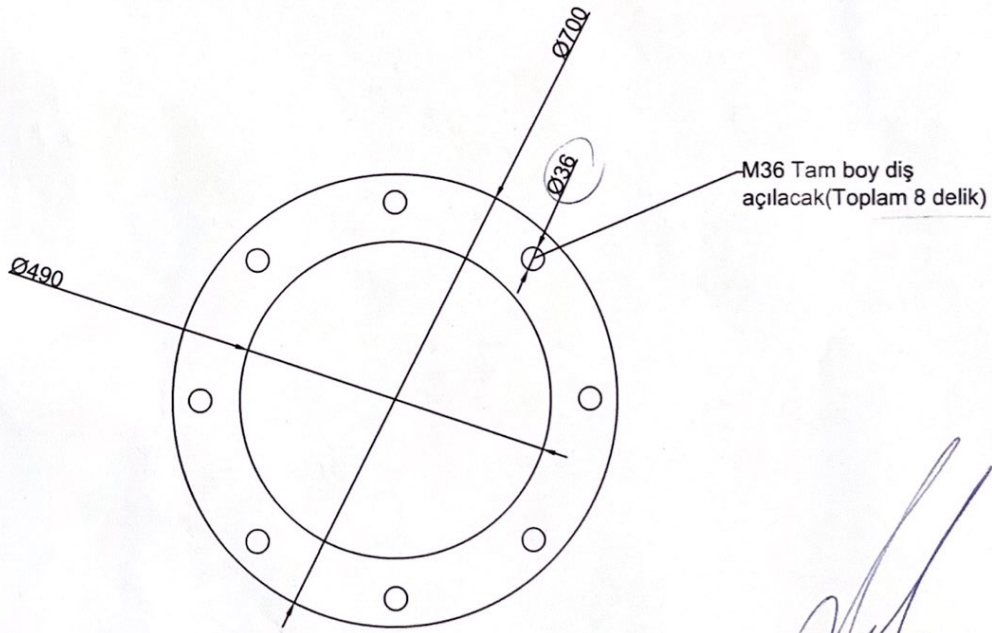
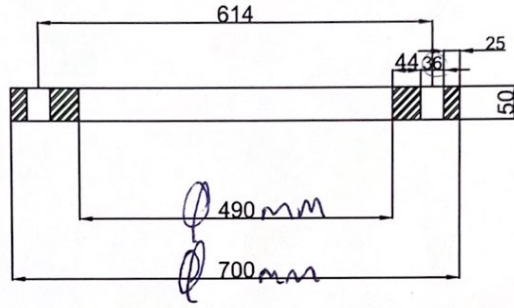

2024.07.02

02.07.2024

Değirmen Roller Bakım Aparatı İmalat Talebi
Malzeme Bilgisi : 1040
Malzeme Kalınlığı: 50 mm

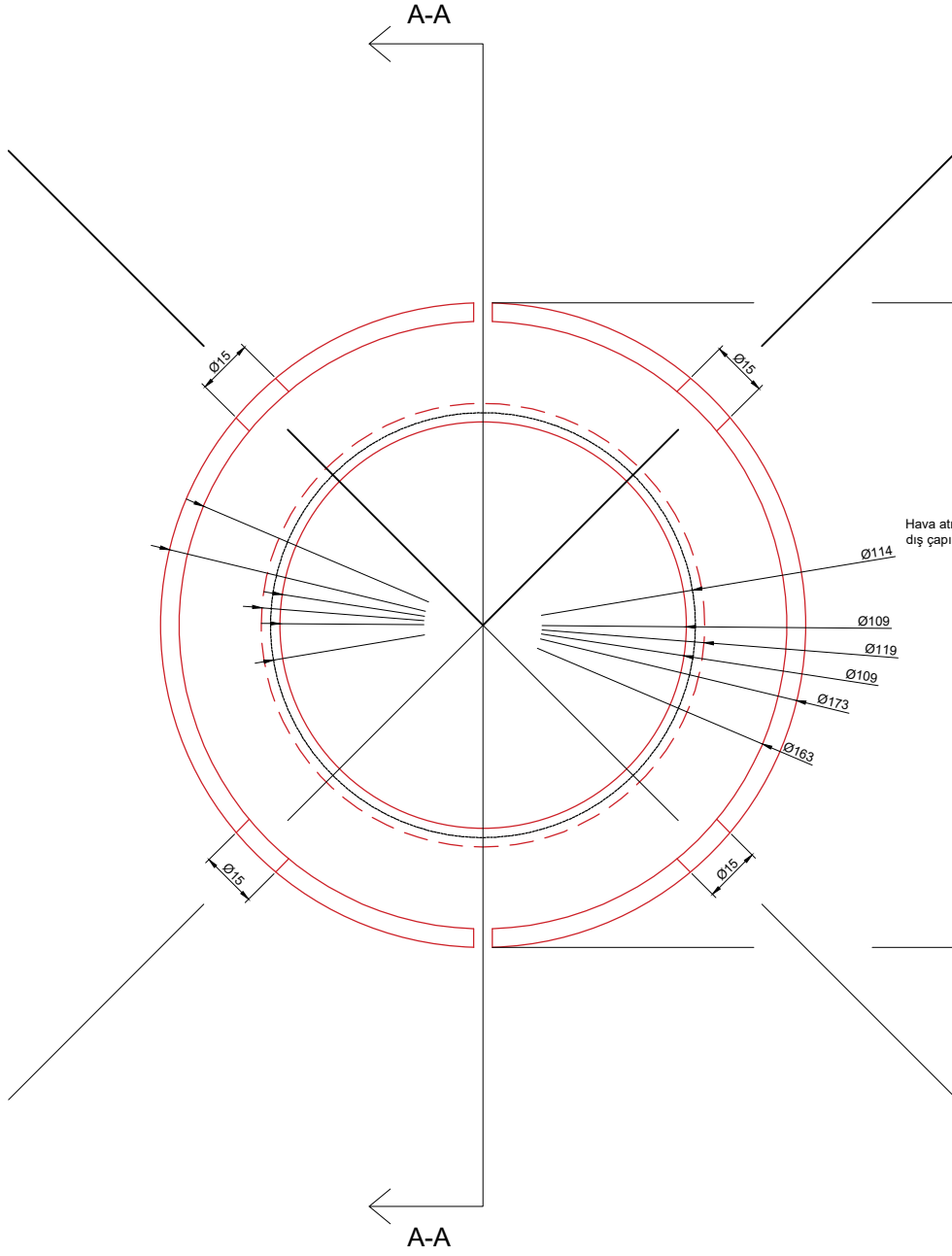

A-A Kesiti

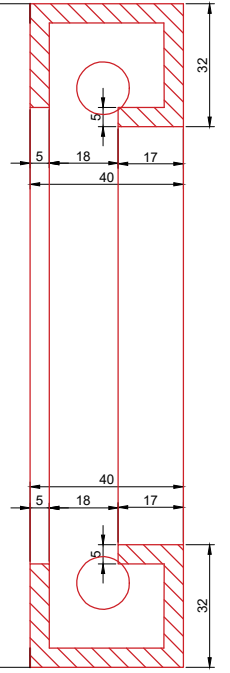

Hava alma kollöktörü  
dış çapı

Ø114

Ø109

Ø119

Ø109

Ø173

Ø163

Ø15

Ø15

Ø15

Ø15

A-A

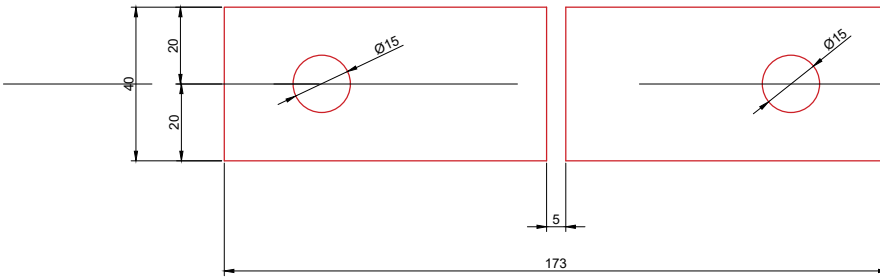

Malzeme Adı:	BFPT Pompo Kollöktör
Malzeme Özelliği:	316ss Paslanmaz
Malzeme Adeti :	8 Adet
Not:Verilen ölçüler mm cinsindedir.	





A505198143-20



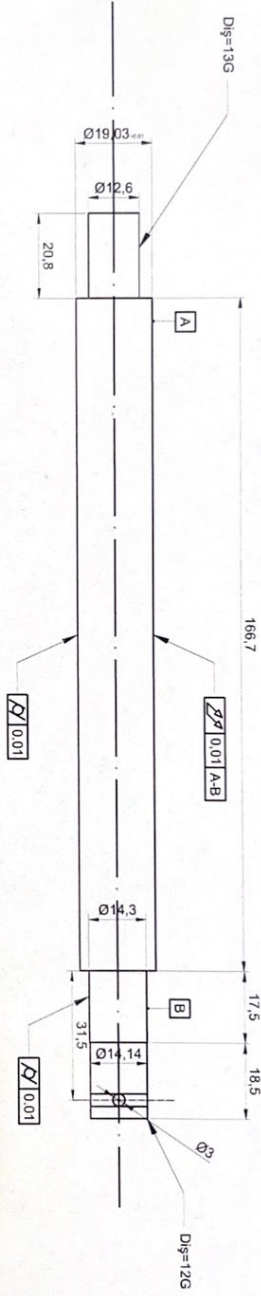

*[Handwritten signature]*  
05.07.2024

*[Handwritten signature]*  
2024.07.05

Amonyak Kompresörü Mil İmalatı Torma  
İşçiliği  
Malzeme Bilgisi: 1040 sertleştirilmiş  
malzeme: 30-32 HRC sertlik istenmektedir.













in mm  
172.75

OFF ON ZERO





in mm  
10.150  
OFF ON ZERO